

EX3600

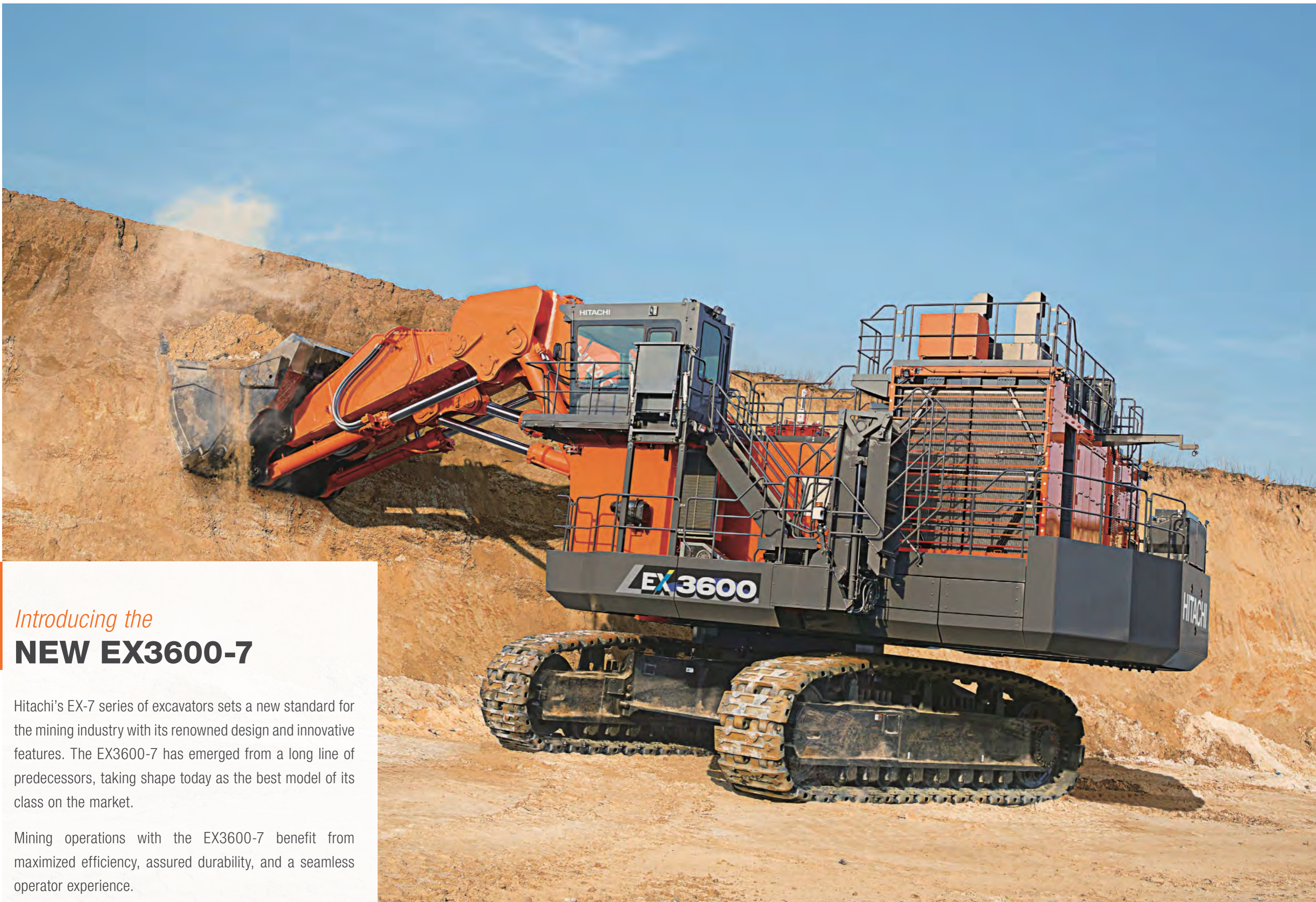

HYDRAULIC EXCAVATOR

Model:	EX3600-7 (Fuel Consumption Optimization)	Model:	EX3600-7B (Tier 4 Final)	Model:	EX3600-7E
Engine Rated Power:	Cummins: 1 450 kW (1 971 PS, 1 944 HP) MTU: 1 450 kW (1 971 PS, 1 944 HP)	Engine Rated Power:	Cummins: 1 450 kW (1 971 PS, 1 944 HP) MTU: 1 500 kW (2 040 PS, 2 010 HP)	Power Output:	1 200 kW (1 632 PS, 1 609 HP)
Operating Weight:	Cummins Loading Shovel: 365 000 kg (804,687 lb.) Backhoe: 366 000 kg (806,892 lb.) MTU Loading Shovel: 366 000 kg (806,892 lb.) Backhoe: 367 000 kg (809,097 lb.)	Operating Weight:	Cummins Loading Shovel: 369 000 kg (813,506 lb.) Backhoe: 370 000 kg (815,710 lb.) MTU Loading Shovel: 366 000 kg (806,892 lb.) Backhoe: 367 000 kg (809,097 lb.)	Bucket:	Loading Shovel: ISO Heaped : 22.0 - 24.0 m ³ (28.8 - 31.4 cu. yd.) Backhoe: ISO Heaped : 22.0 - 24.0 m ³ (28.8 - 31.4 cu. yd.)
Bucket:	Loading Shovel: ISO Heaped : 22.0 - 24.0 m ³ (28.8 - 31.4 cu. yd.) Backhoe: ISO Heaped : 22.0 - 24.0 m ³ (28.8 - 31.4 cu. yd.)	Bucket:	Loading Shovel: ISO Heaped : 22.0 - 24.0 m ³ (28.8 - 31.4 cu. yd.) Backhoe: ISO Heaped : 22.0 - 24.0 m ³ (28.8 - 31.4 cu. yd.)		



Introducing the **NEW EX3600-7**

Hitachi's EX-7 series of excavators sets a new standard for the mining industry with its renowned design and innovative features. The EX3600-7 has emerged from a long line of predecessors, taking shape today as the best model of its class on the market.

Mining operations with the EX3600-7 benefit from maximized efficiency, assured durability, and a seamless operator experience.

designed for SUSTAINABILITY

Hitachi's energy optimization technologies are kinder to the planet and reduce consumption costs while achieving superior productivity.

The EX3600-7 features a selection of engine configurations to meet regulatory requirements, electronically controlled hydraulic pumps, an optimized cooling package, and enhanced hydraulic circuits for a sustainable solution that doesn't compromise on performance.

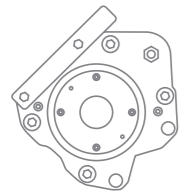

MAIN PUMP ELECTRIC REGULATORS

Each individually controlled hydraulic pump has its own electric regulator, enhancing engine power, lowering fuel consumption, and increasing productivity to lower the total cost of operation.

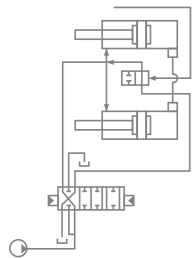

HYDRAULIC REGENERATION CIRCUIT

The flow regeneration valve fitted to the hydraulic system reduces pump demand, ultimately reducing power requirements from the hydraulic system and engine. The result is lower fuel consumption and improved pump life.

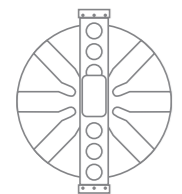

HYDRAULIC OIL COOLER

A larger hydraulic oil cooler with variable speed fan reduces energy demand and creates a more reliable hydraulic system. The oil cooler is kept separate from the radiator to effectively reduce hydraulic oil temperatures, increase hydraulic service life, and improve maintainability.

ENGINE OPTIONS

CUMMINS

Cummins QSK60, 16 cylinder, 60.0 L (3,661 cu. in.), turbo-charged, after-cooled 1 450 kW (1 971 PS, 1 944 HP)

Options:

Cummins diesel engine U.S.A. E.P.A. Tier 4 conforming model, with Diesel Exhaust Fluid (DEF) tank

Cummins diesel engine Fuel Consumption Optimization (FCO) model

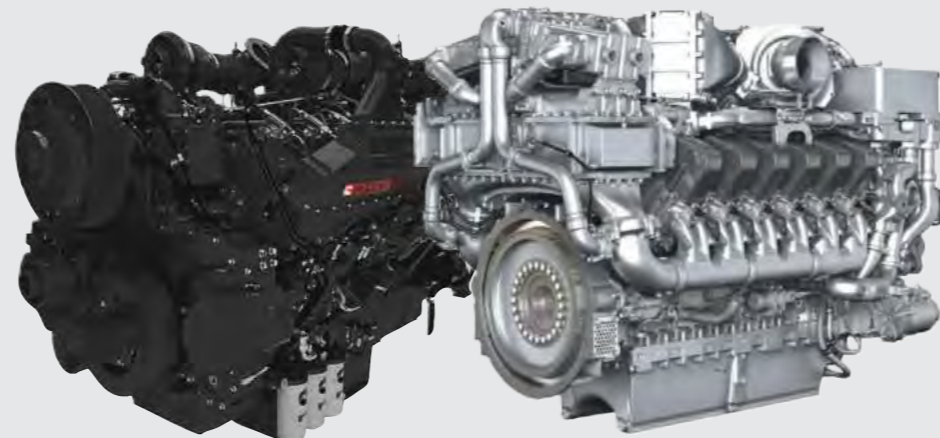

MTU

MTU 12V4000, after-cooled, 12 cylinder, 57.2L (3,491 cu. in.)

Options:

MTU diesel engine U.S.A. E.P.A. Tier 4 conforming 2-stage turbo-charged model 1 500 kW (2 040 PS, 2 010 HP)

MTU diesel engine Fuel Consumption Optimization (FCO) single stage turbo-charged model 1 450 kW (1 971 PS, 1 944 HP)

HITACHI AC ELECTRIC MOTOR

The EX3600-7E electric excavator is available, operating with the Hitachi AC electric motor

Options:

electric motor (1 200 kW (1 632 PS, 1 609 HP)) 50Hz, 6 000 V, 6 600 V*

electric motor (1 200 kW (1 632 PS, 1 609 HP)) 60Hz, 6 600 V, 6 900 V*

*Please contact hitachi for other specification request



designed for
PRODUCTIVITY

Equipped with more than 100 years of technological innovation from Hitachi, Ltd. group companies, our EX-7 excavators are engineered to achieve more for your mine site.

The EX3600-7 delivers exceptional around-the-clock performance while optimizing consumption, taking productivity to a new level.

FRONT ATTACHMENT

With a front attachment design that prioritizes performance, the EX3600-7 can achieve superior productivity under different digging profiles.

The boom and arm are strategically welded, utilizing a full-box section design to evenly distribute stress and provide ease of maintenance.

**LOADING SHOVEL
 EXCAVATING FORCE**

The Loading Shovel attachment is equipped with an auto-leveling crowd mechanism that controls the bucket at a constant angle. The EX3600-7 now has a larger 22.0 m³ (28.8 cu. yd.) bucket, designed to enhance loading capability with a tilt angle that enhances operational efficiency.

**BACKHOE
 EXCAVATING FORCE**

The Backhoe attachment is designed using computer aided box frame analysis to determine the optimal structure for integrity and longevity. Complete with a floating pin and bush, the bucket has been designed to match the geometry of the attachment to maximize productivity.

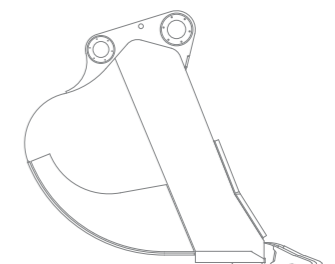
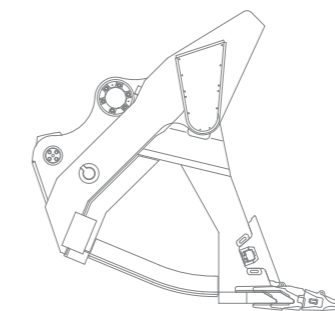

LOADING SHOVEL

Arm crowding force on ground
 1 190 kN (121 000 kgf, 267,523 lbf.)

Bucket digging force
 1 030 kN (105 000 kgf, 231,533 lbf.)

BACKHOE

Arm crowding force
 951 kN (97 000 kgf, 213,793 lbf.)

Bucket digging force
 1 050 kN (107 000 kgf, 236,049 lbf.)

designed for
SAFETY

Safety is Hitachi's ultimate priority, realized in the EX-7 series of excavators with a range of intelligent safety-focused designs.

The EX3600-7 includes spacious walkways, improved handrails, and important safety features like an on-board inclinometer and dual isolator switch as standard.

ACCESS AND WALKWAYS

Anti-slip walkways and specially designed handrails reduce the risk of tripping when maneuvering around the machine and provide ease of access for operators and maintenance personnel.

Wide, low-gradient, non-slip, hydraulic folding stairs allow for easy and safe access to the machine.



ON-BOARD INCLINOMETER

The on-board inclinometer assists the operator to work within the safe limits of the machine, with two predetermined safety limits providing extra assurance. If the first safety limit is exceeded, the operator receives a visual alert prompting them to take corrective action. The alert escalates to an audible alarm if the second safety limit is breached.

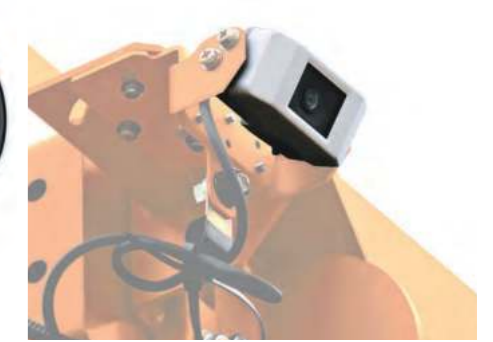

PERIMETER MONITORING CAMERAS (OPTIONAL)

Optional perimeter monitoring cameras offer better visibility of a surrounding area, reducing blind spots for the operator. Two cameras are located at both the front and rear of the excavator, and are linked to monitors inside the cab.



EMERGENCY ESCAPE CHUTE

An escape chute has been added to the side of the cab for use in an emergency. The chute allows evacuees to descend vertically down from the machine, providing a safe and fast route of escape when all other means of exit are blocked.

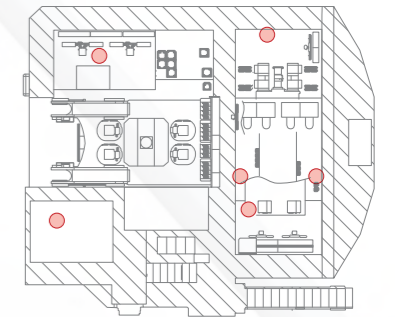

ENGINE STOP SWITCHES

Engine stop switches have been placed in easily accessible areas: two in the engine room, one in the pump room, one in the oil cooler room, one in the radiator room, and one emergency stop switch in the cab.

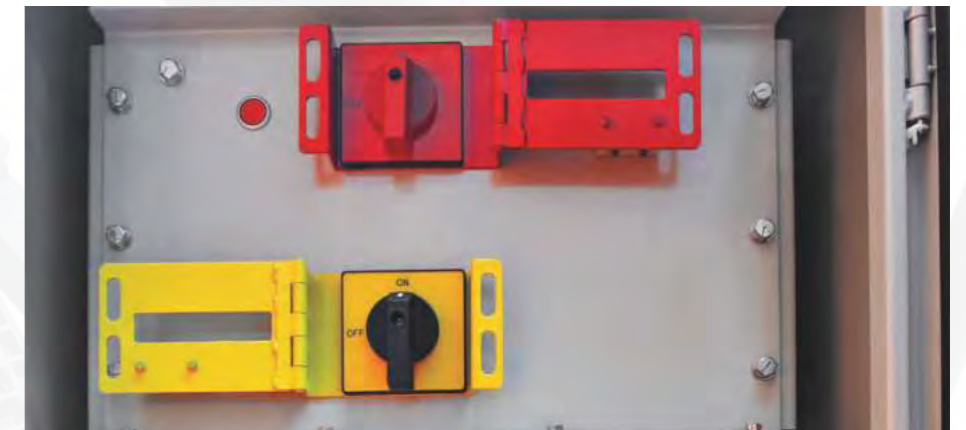

DUAL ISOLATOR SWITCH

The conveniently located dual isolator switch offers the option to deactivate the engine and battery individually.

When inspections and maintenance are required, the battery isolator provides the benefit of isolating both the positive and negative terminals of the battery for a safe working environment. The engine isolator deactivates the engine starter motor while allowing battery power to the electric system for troubleshooting to enhance safety and maintainability.

designed for

OPERATOR COMFORT

Hitachi's EX3600-7 maximizes productivity by giving operators complete comfort and control in the cab. Features include ergonomic layout, electronic joysticks, intelligent Multi-Functional Display, advanced air suspension seating, and better climate control to make for effortless operation.



CLIMATE CONTROLLED AIR CONDITIONING

The pressurized cab's climate controlled air conditioning helps to overcome environmental extremes. Optimized filtering of interior and exterior air combined with the new flexi-vent system provides a personalized and balanced environment that meets operator demands.



OPERATOR SEAT

Specifically designed for use in the mining industry, the automatic weight-adjusting air suspension seat calculates optimal cushioning to match the operator's weight, enhancing comfort and minimizing vibration.



ELECTRONIC JOYSTICKS

Integrated electronic joysticks connected to the machine's microprocessor enable precise and almost effortless operation, minimizing operator fatigue and improving operational performance.

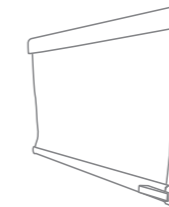

ROLL SCREENS

Retractable front and side roll screens protect the operator from UV glare and reduce heat buildup in the cab, improving the efficiency of the climate controlled air conditioner for a superior operating environment.

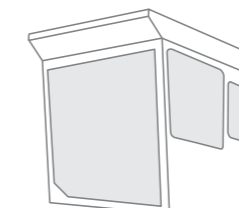

OPERATOR CABIN

The use of laminated tinted windows reduce heat and glare in the cab, while sound-suppression further enhances ergonomics and comfort for the operator.

The Level II Operator Protective Guard (OPG) provides secure protection from falling objects, ensuring operator safety.

MULTI-FUNCTIONAL DISPLAY

Fitted with an LED back-light to improve clarity and reduce glare, the multi-functional display provides key machine information and performance indicators through use of an integrated dial switch interface.

designed for

EASE OF MAINTENANCE

Hitachi's EX-7 series of excavators are now easier and safer to maintain than ever before with an intuitive design. The EX3600-7 features a spacious modular layout with open passageways and work platforms to simplify daily upkeep and major component inspections.



AUTO-LUBRICATION SYSTEM

A new auto-lubrication system comes with 380 L (132.1 gal.) large capacity grease tank, new grease pump, in-line grease filter with breather, grease level indicator in cab and provision for fitment of a second grease pump in the lubrication tank. These features provide a more reliable system with less downtime.



GREASE-LESS CENTER JOINT

The new center joint employs the machine's hydraulic oil to self-lubricate, reducing the need for daily maintenance.



LUBRICATION PIPING COVER

A swing circle cover has been added to the outside of the swing bearing, protecting the lubrication piping from debris damage.



CENTRALIZED LUBRICATION SYSTEM

The centralized fast-filling system provides easy access from the ground to refill and evacuate lubricants, water, grease and fuel. The fast-filling system can be fitted with an optional quick coupler.

MAINTENANCE ACCESS

Wide center walkways and open service areas offer ease of access for daily maintenance tasks and make engine, hydraulic, and electrical component inspections easy.

CONTAMINATION SENSORS

Contamination sensors are located on main hydraulic pumps, travel motors and swing motors to detect any contaminants that may cause damage to the hydraulic system. Sensors alert the operator of potential contaminants and record the fault code in the Data Logging Unit (DLU) with the capability to remotely advise maintenance personnel.

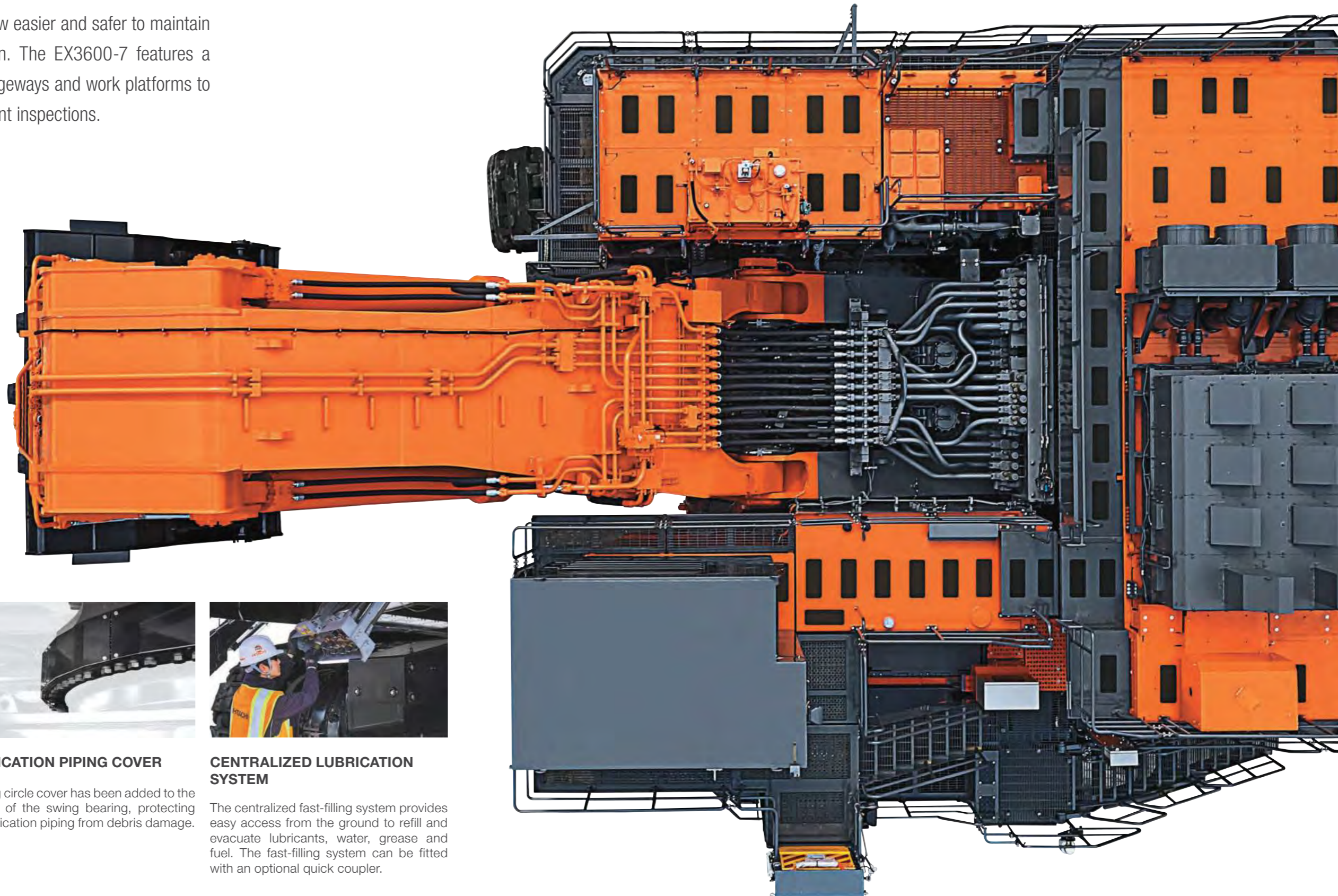



designed for
DURABILITY

Hitachi's EX-7 excavators have been built to withstand the harshest mining conditions while delivering outstanding productivity. Advanced computer modelling, specialized forgings, and pedestal design track shoes are just some of the features that make the EX3600-7 one of the most durable excavators on the market.

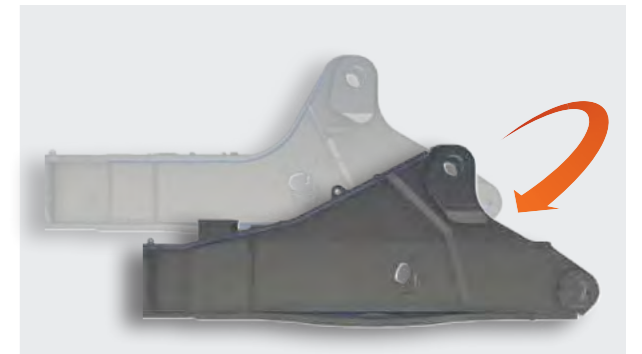

STRONG MAINFRAME

The EX3600-7 features a stronger, more durable mainframe than previous models. Stress is now more evenly dispersed across the improved frame shape, increasing machine durability and reducing downtime.

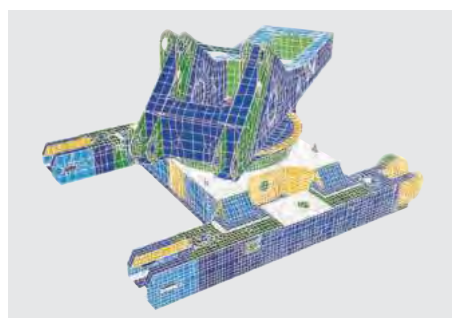

RIGID BOX DESIGN

Computer assisted analysis has been used to determine the most effective design for frame longevity, ensuring the EX3600-7 withstands the demands of any mining operation.



CENTER TRACK FRAME

Hitachi's exclusive center track frame delivers optimal stress dispersion through the use of specially designed forged steel parts to reduce the chance of failure in critical high-stress areas. This guarantees a stronger frame with improved durability.



UPPER ROLLERS

The EX3600-7 undercarriage has three double-sided, pedestal-designed upper rollers on each side of the track frame. These rollers maintain track shoe clearance and provide protection from debris buildup, reducing shoe and roller wear for a more reliable undercarriage system.



OIL-FILLED ROLLERS & IDLERS

The oil-filled idlers and upper and lower rollers eliminate the need for daily lubrication, helping reduce maintenance costs.



TRACK SHOES

Hitachi's classic track shoe design has been applied to mitigate premature wear of the drive-lugs. Each shoe is induction hardened using Hitachi's proven methods to deliver a superior and more durable solution.



CENTER FRAME UNDERGUARD (OPTIONAL)

A newly designed heavy duty guard protects hoses and accumulators located in the track center frame from rocks and debris ingress, providing extra protection and reliability.



designed for
RELIABILITY

Hitachi's EX-7 series is loaded with intelligent features which minimize downtime and optimize excavator longevity. The EX3600-7 is meticulously designed to provide a reliable solution every hour of the day.



FRONT ATTACHMENT HOSES

Hitachi's hose design has been tested on a high cyclic fatigue rate to maximize longevity and improve safety. Front attachment hoses have been rearranged from the traditional arch style to an underslung configuration, removing the need for clamping, reducing chafing and increasing reliability.

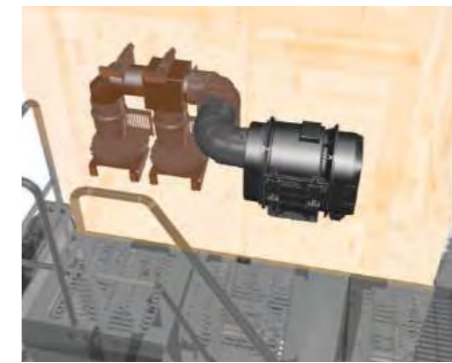

CAB RISER PRESSURIZER

The cab riser now features a pressurizer system to reduce dust infiltration, extending the service life of the electronic components and devices within.



SOLID CONDUIT WIRE HARNESSSES

Newly introduced solid conduit harnesses and junction boxes prevent dust and moisture ingress, improving longevity. Electrical harnesses between junction boxes can be replaced individually, reducing maintenance time and cost.



OPERATING LIGHTS

Strategically placed long-life LED working lights provide assured reliability for night operations.



ELECTRONIC CYLINDER STROKE CONTROL

The new on-board electronic controller receives signals from angle sensors fitted to the main frame, boom and arm to control the pump flow rate and cylinder speed. Shock at stroke end of the cylinder cycle is reduced, improving operator comfort and lowering impact on cylinders and structures for more reliable operation.

designed for INTELLIGENCE

Hitachi's EX-7 excavators are leading the mining industry toward smarter operations that can achieve more than ever before. On-board sensors, diagnostic tools, real-time data and intelligent software empower mine sites to operate the EX3600-7 to its full potential.

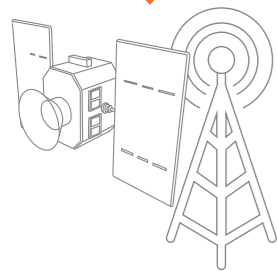

ANTENNA (GPRS) OR SATELLITE

SATELLITE / GPRS COMMUNICATION (OPTIONAL)

Standard machine information is transmitted daily through either satellite or GPRS (General Packet Radio Service) communication, sending data directly to the Hitachi Global e-Service platform to support the mining operation.

Globale-Service

Global e-Service is a Hitachi web-based platform that sends vital machine information directly to the customer in a readily accessible format.

WIRELESS INTERFACE

Detailed machine information can be remotely downloaded from the Data Logging Unit (DLU) via the Wireless Interface Unit (WIU), providing vital operational & performance data.

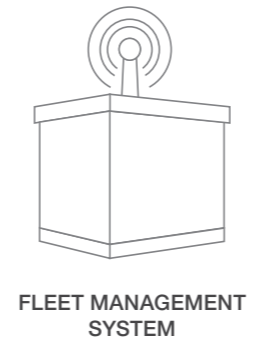
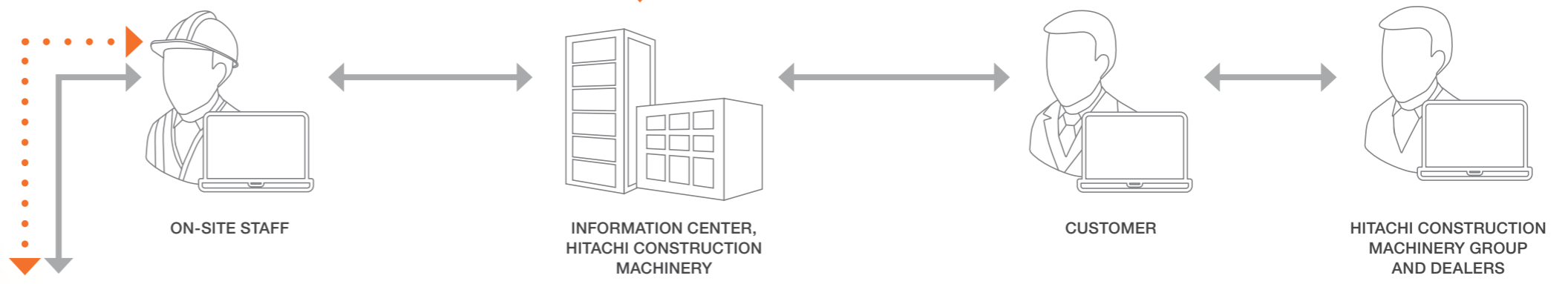

FLEET MANAGEMENT SYSTEM



The DLU can be combined with Wenco or another third party fleet management system to provide live operational and performance information, assisting with fleet management.



Aerial Angle (OPTIONAL)

Aerial Angle provides the operator with a 360° live view around their excavator. Cameras strategically mounted on the machine generate a single aerial view of the EX3600-7 surroundings. Multiple screen display options can be selected on the cab's 12 inch Aerial Angle monitor for ease of operation.

SPECIFICATIONS

WORKING RANGES

Loading Shovel

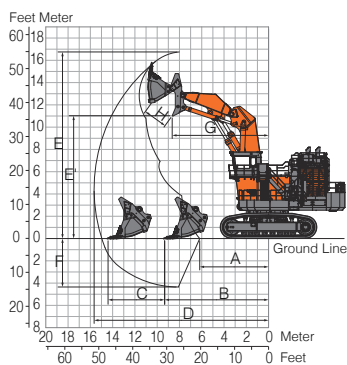

Bucket Capacity	22.0 m ³ (28.8 cu. yd.)
A: Minimum Digging Distance	6 180 mm (20 ft. 3 in.)
B: Minimum Level Crowding Distance	9 330 mm (30.6 ft.)
C: Level Crowding Distance	5 080 mm (16.7 ft.)
D: Maximum Digging Reach	15 660 mm (51 ft. 5 in.)
E: Maximum Cutting Height	16 750 mm (54 ft. 11 in.)
F: Maximum Dumping Height	10 990 mm (36 ft. 1 in.)
G: Maximum Digging Depth	4 350 mm (14 ft. 3 in.)
H: Working Radius at Maximum Dumping Height	8 650 mm (28.4 ft.)
Maximum Bucket Opening Width	1 950 mm (6 ft. 5 in.)
Arm crowding force on ground	1 190 kN (121,000 kgf, 267,523 lbf)
Bucket digging force	1 030 kN (105 000 kgf, 231,553 lbf)

Backhoe

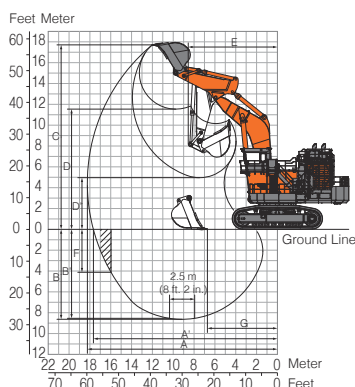

BE-boom length	9.6 m (31 ft. 6 in.)
BE-arm length	4.5 m (14 ft. 9 in.)
Bucket capacity (ISO heaped)	22.0 m ³ (28.8 cu. yd.)
A: Maximum Digging Reach	18 240 mm (59 ft. 10 in.)
A': Maximum Digging Reach (on ground)	17 660 mm (57 ft. 11 in.)
B: Maximum Digging Depth	8 630 mm (28 ft. 4 in.)
B': Maximum Digging Depth (2.5 m (8 ft. 2 in.) level)	8 540 mm (28 ft.)
C: Maximum Cutting Height	17 710 mm (58 ft. 1 in.)
D: Maximum Dumping Height	11 540 mm (37 ft. 10 in.)
D': Minimum Dumping Height	4 960 mm (16 ft. 3 in.)
E: Minimum Swing Radius	8 560 mm (28 ft. 1 in.)
F: Maximum Vertical Wall	4 180 mm (13.7 ft.)
G: Minimum Level Crowding Distance	6 720 mm (22 ft.)
Bucket Digging Force (ISO)	1 050 kN (107 000 kgf, 236,049 lbf)
Arm Crowd Force (ISO)	951 kN (97 000 kgf, 213,793 lbf)

DIMENSIONS

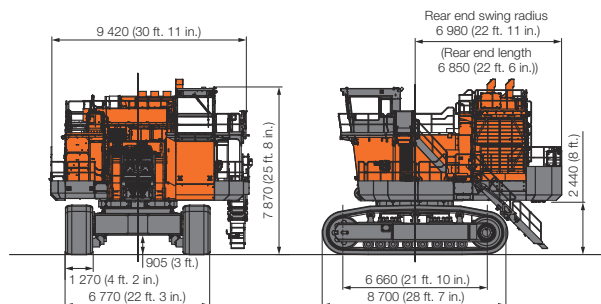

PASS MATCH

Best match: 4–6 passes

Potential match: 3–8 passes

Model		100t class truck	EH3500AC-3	EH4000AC-3	EH5000AC-3
EX2600-7	BH 17.0m ³ (22.2 cu. yd.)	3	6	8	
	LD 15.0m ³ (19.6 cu. yd.)	4	8		
EX3600-7	BH 22.0 m ³ (28.8 cu. yd.)	3	5	6	8
	LD 22.0 m ³ (28.8 cu. yd.)	3	5	7	
EX5600-7	BH 34.0m ³ (44.4 cu. yd.)		3	4	5
	LD 29.0m ³ (37.9 cu. yd.)		4	5	7

UPPER STRUCTURE

Swing speed	3.2 min ⁻¹ (rpm)
Fuel tank capacity	7 450 L (1 639 gal.)
DEF tank capacity (Cummins T4F only)	475 L (104.5 gal.)

HYDRAULIC SYSTEM

Main Pumps	8 variable-displacement, axial piston pumps for front attachment, travel and swing
Pressure setting	29.4 MPa (300 kgf/cm ² , 4 264 psi)
Max. oil flow	8 x 500 L/min (132 gal./min)

UNDERCARRIAGE

Travel speeds	High : 0 to 2.2 m/h (0 to 1.4 mph) Low : 0 to 1.7 km/h (0 to 1.1 mph)
Maximum traction force	1 760 kN (179 000 kgf, 395,664 lbf)

WEIGHTS AND GROUND PRESSURE

Loading Shovel

Equipped with 22.0 m³ (28.8 cu. yd.) (ISO heaped) bottom dump bucket

Shoe width	Weight	Ground pressure
1 270 mm (50 in.)	369 000 kg (813,506 lb.)	193 kPa (1.97 kgf/cm ² , 28 psi)

Backhoe

Equipped with 22.0 m³ (28.8 cu. yd.) (ISO heaped) bucket

Shoe width	Weight	Ground pressure
1 270 mm (50 in.)	370 000 kg (815,710 lb.)	194 kPa (1.98 kgf/cm ² , 28.1 psi)

Cummins T4F configuration

ATTACHMENTS

Loading Shovel

Bucket Capacity (ISO heaped)

22.0 m³ (28.8 cu. yd.) : Material density 1 800 kg/m³ (3,034 lb./cu. yd.) or less
24.0 m³ (31.4 cu. yd.) : Material density 1 600 kg/m³ (2,697 lb./cu. yd.) or less

Backhoe

Bucket Capacity (ISO heaped)

22.0 m³ (28.8 cu. yd.) : Material density 1 800 kg/m³ (3,034 lb./cu. yd.) or less
24.0 m³ (31.4 cu. yd.) : Material density 1 600 kg/m³ (2,697 lb./cu. yd.) or less

ENGINE

Model Cummins QSKTA60-CE (FCO, T4F)

Rated power @1 800 min⁻¹(rpm)

ISO 14396 1 450 kW (1 971 PS, 1 944 HP)

Piston displacement 60.0 L (3,661 cu. in.)

Model MTU 12V4000 C33 (FCO)

Rated power @1 800 min⁻¹(rpm)

ISO 14396 1 450 kW (1 971 PS, 1 944 HP)

Piston displacement 57.2 L (3,491 cu. in.)

Model MTU 12V4000 C35 (T4F)

Rated power @1 800 min⁻¹(rpm)

ISO 14396 1 500 kW (2 040 PS, 2 010 HP)

Piston displacement 57.2 L (3,491 cu. in.)

ENVIRONMENT

Auto control air conditioner contains fluorinated greenhouse gases.

Refrigerant type: HFC-134a, GWP: 1430, Amount: 2.85 kg (6.3 lb.), CO₂e: 4.08 tonnes (4.50 tons).

Before using a machine with a satellite communication system or telecommunication system, please make sure that the satellite communication system or telecommunication system complies with local regulations, safety standards and legal requirements. If not so, please make modifications accordingly.

These specifications are subject to change without notice. Illustrations and photos show the standard models, and may or may not include optional equipment, accessories, and all standard equipment with some differences in color and features. Before use, read and understand the Operator's Manual for proper operation.